

INVESTIGATION INTO THE RE-HYDRATION OF MICROWAVE DRIED CARROT UNDER REDUCED PRESSURE

Ryszard Kramkowski, Marian Szarycz, Bogdan Stepień, Marcin Fidos

Institute of Agricultural Engineering, University of Agriculture
ul. Norwida 25, 53-375 Wrocław
e-mail: kramkowski@imr.ar.wroc.pl

Abstract. The kinetics of the rehydration of the 'Perfekcja' variety of carrot, microwave dried under reduced pressure has been studied. The pressure ranged from 6 kPa to 8 kPa and the microwave heating time was 18, 21, 24, 27 and 30 minutes. Rehydration was carried out in water at a temperature of 20°C for 0 to 180 minutes and in water at a temperature of 95°C for 0 to 120 minutes. The results obtained were compared with Peleg's model.

Key words: rehydration, partial pressure, microwaves, carrot, Peleg's equation

INTRODUCTION

In food processing, it is very important to obtain products of the highest quality. The drying process changes the form and properties of the material processed. The changes, besides a reduction in water content, usually result in a reduction of volume and density. These are quite positive changes from the point of view of storage capacity and transportation. However, the drying process causes numerous disadvantageous changes consisting of the degradation of valuable components due to increased temperature and contact with oxygen.

The reduced pressure drying process is a technique which restricts contact with oxygen. Additionally, it is possible to conduct the process at lower temperature than it is by more conventional methods. One of the most modern methods for supplying energy is the application of alternate electromagnetic fields with the desired frequencies.

The application of this method – i.e. microwave drying under reduced pressure, results in a high quality product in the form of the dried material. The factor which determines the quality of the dried material is its ability to rehydrate. The course of

the rehydration process is of great importance for the final quality of any dried material obtained [4,5].

MATERIAL AND METHODS

Carrot, of the 'Perfekcja' variety, cut into 10 mm cubes, was used in the investigation. Cutting was carried out with a blade die ensuring regularity of shape and maintaining the dimensions within the limit of 0.2 mm. After cutting, the material was subjected to blanching in water at a temperature of 96°C for 3 min. After drying on filter paper, 100 g batches were weighed, vacuum packed and deep frozen to a temperature of -27°C for 24 hours.

After defrosting the material with the use of microwaves, 45 g samples were weighed on a RADWAG scale of the WPE 600 type, allowing measurement accuracy within 0.01 g. The samples were then dried in a laboratory plant as shown in figure 1.

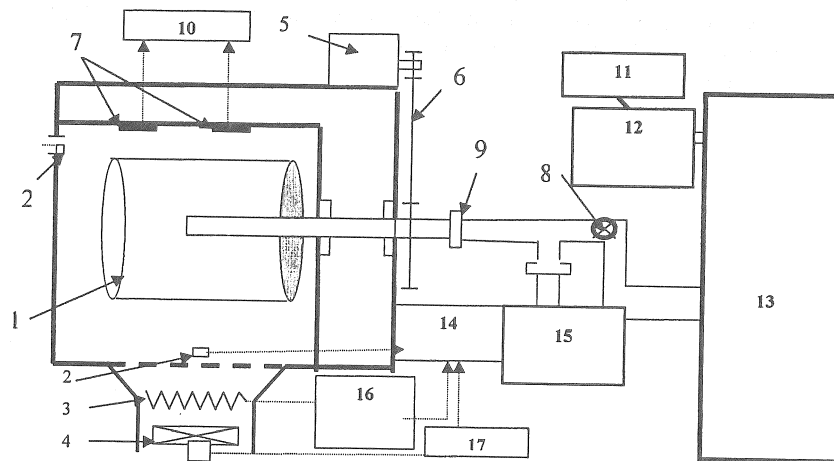

Fig. 1. A scheme of the experimental plant.

1- drying chamber, 2 - temperature sensor, 3 - heaters, 4 - fan, 5 - electric motor, 6 - gear, 7 - magnetron, 8 - cut off valve, 9 - connector, 10 - control system of microwave power, 11 - control system of vacuum pump, 12 - vacuum pump, 13 - equalising tank, 14 - temperature control system, 15 - pressure meter, 16 - control system of heaters power, 17 - fan control system.

A drying chamber (1) made of glass with a low dielectric loss coefficient is an essential part of the plant. The system, which enables rotation of the chamber during drying assures evenly distributed heating of the samples. The system consists of a repulsion motor – (5) and a gear – (6). The chamber is placed inside the microwave cavity, where the air, heated at a given temperature, circulates. The electromagnetic field inside the cavity is generated with two magnetrons – (7) with a maximum power of 1200 W. The intensity of the power of the magnetrons is controlled.

Axially, in the chamber there is a channel for the transport of water vapour into the equalising tank. The connector – (9) enables rotation of the drying chamber.

The power of the magnetrons in the drier was 480 W. The partial pressure sensor was adjusted to a pressure ranging from 6 to 8 kPa which enabled the pump to be switched on and off. Successive experiments lasted for 18, 21, 24, 27 and 30 minutes. The moisture was, correspondingly, 43, 28, 18, 15 and 11%.

Rehydration, i.e. re-watering of the material was carried out with distilled water at temperatures of 20°C and 95°C. The dry mass content was determined according to the PN-90/A-75101 standard. For maintaining the water temperature constant during the rehydration of the dried material, the plant shown in figure 2 was used.

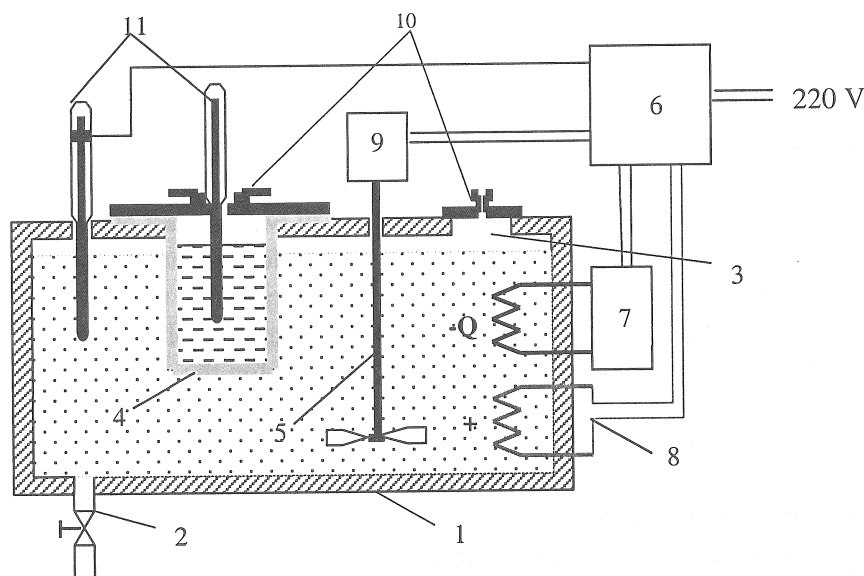

Fig. 2. Block diagram of the rehydration stand.

1 – isothermal tank with liquid, 2 – draining valve, 3 – inlet, 4 – metal container with liquid for rehydration, 5 – mixer, 6 – control system, 7 – cooling system, 8 – heater, 9 – electric motor, 10 – cover, 11 – thermometer

The metal container with the distilled water for rehydration was placed in an insulated tank. The container with the processing liquid was equipped both with an electric heater and a cooling system. The rehydration process was started after equalising the temperature in both containers. For measuring the temperature, a mercury thermometer was used (measurement accuracy within $\pm 1^\circ\text{C}$).

For a simulation of the rehydration process, Peleg's equation [1] has been applied.

$$u_t = u_o + \frac{t}{K_1 + K_2 t} \quad (1)$$

The equilibrium of the water content in the material can be determined by the equation:

$$u_r = u_o + \frac{1}{K_2} \quad (2)$$

The water content in the material was expressed by an increase in the water mass content for every 100 g of initial dry substance. At such an assumption, $u_o = 0$. In order to assess the usefulness of Peleg's model to describe the rehydration of raw carrot, the relative error value of each measurement point, for all rehydration curves, was estimated.

RESULTS AND DISCUSSION

The kinetics of the water content which increase during the rehydration process at 20°C and 95°C is shown in figures 3 and 4, respectively.

At the first stage of the process, the absorption of water is fast but it decreases progressively with the rehydration time. The graphs for the successive times of magnetron exposure, at a constant rehydration temperature (20°C and 95°C) climb higher and higher indicating the considerable regularity of the process.

Figures 5 and 6 show the course of rehydration for the extreme exposure times of the magnetrons (the shortest is 18 min., the longest 30 min.). It can be seen that increasing the time of magnetron exposure results in significant acceleration of the rehydration process. For example, the values of water content at a rehydration temperature of 95°C and a time of 30 min differ from each other twice and the ratios of water content to initial dry substance amount to ca. 300g water/100 g substance and above 600 g water/100 g substance, respectively.

In tables 1 and 2 the values of the K_1 and K_2 constants together with the appropriate values for determining coefficients have been presented.

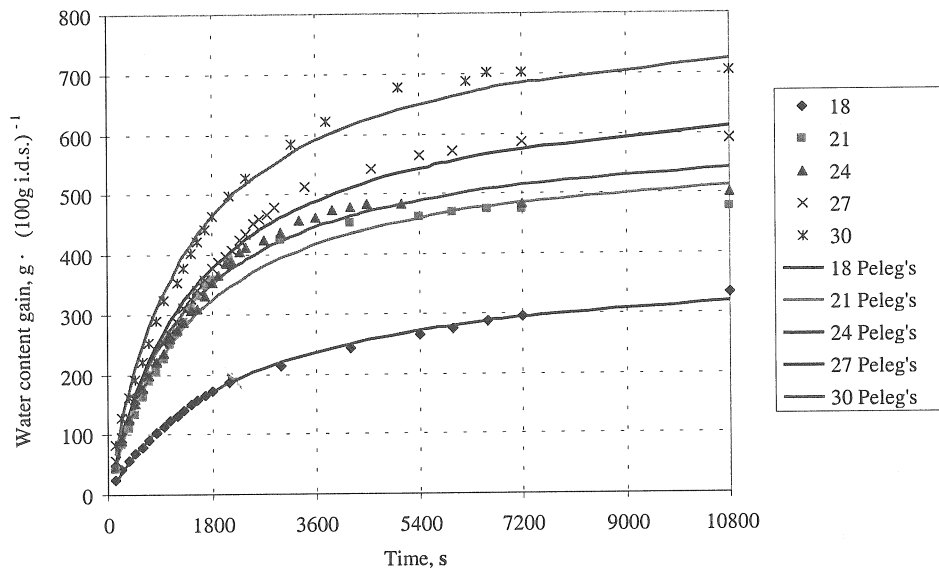

Fig. 3. Comparison of the experimental results with Peleg's model at a rehydration temperature of 20°C

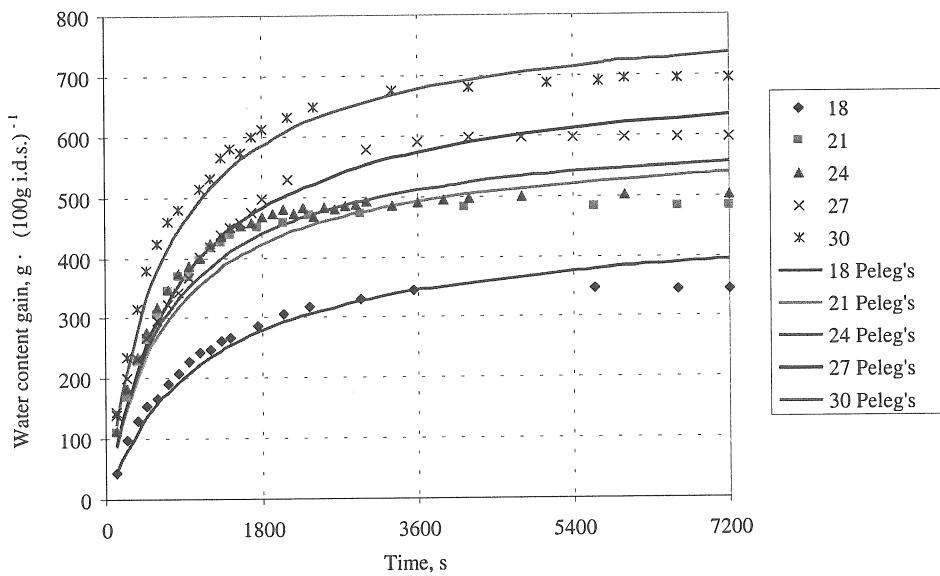

Fig. 4. Comparison of experimental results with Peleg's model at a rehydration temperature of 95°C

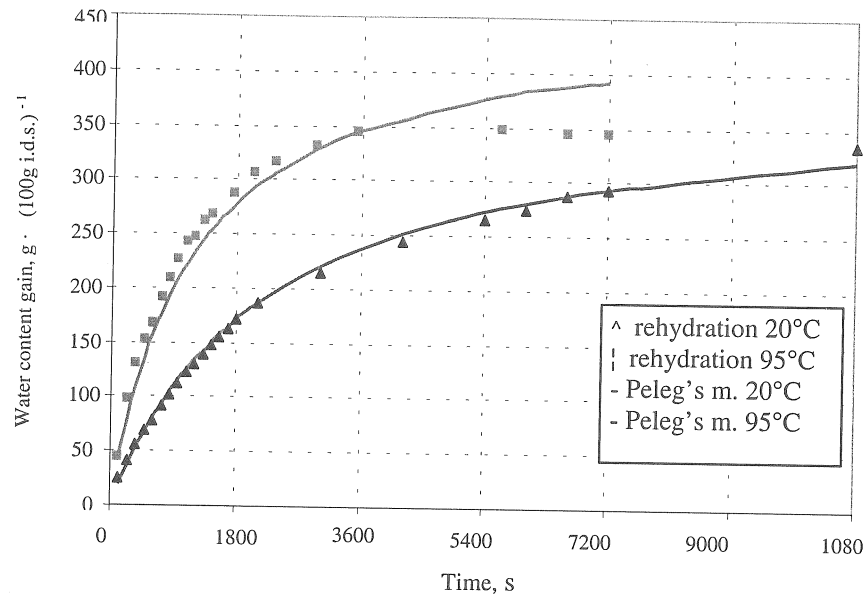

Fig. 5. Rehydration for 18 min duration of magnetron exposure

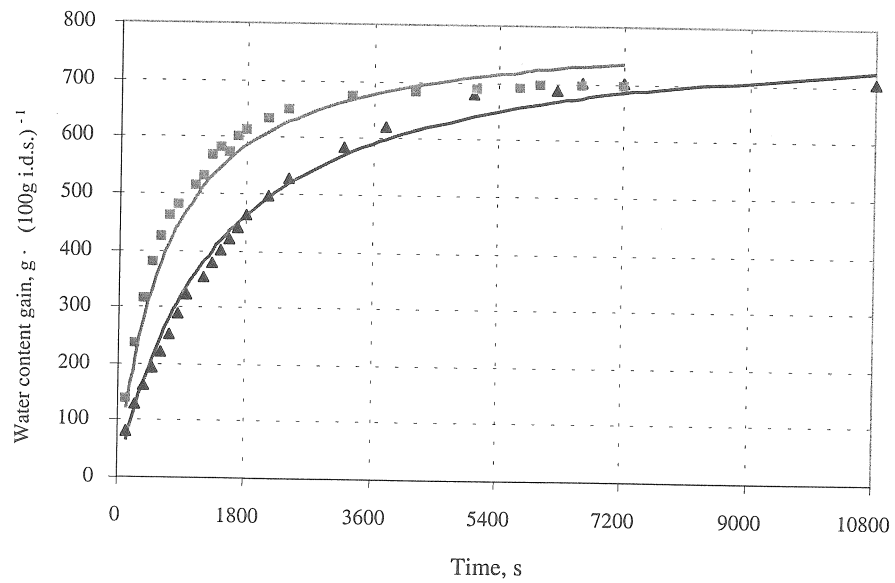

Fig. 6. Rehydration for 30 min duration magnetron exposure

Table 1. The values of K_1 and K_2 constants from Peleg's equation at $t = 20^\circ\text{C}$

Time of magnetron Exposure (min)	K_1	K_2	R^2
18	5.83	$2.59 \cdot 10^{-3}$	0.974
21	2.46	$1.72 \cdot 10^{-3}$	0.967
24	2.26	$1.64 \cdot 10^{-3}$	0.964
27	2.19	$1.44 \cdot 10^{-3}$	0.972
30	1.68	$1.23 \cdot 10^{-3}$	0.988

Table 2. The values of K_1 and K_2 constants from Peleg's equation at $t = 95^\circ\text{C}$

Time of magnetron Exposure (min)	K_1	K_2	R^2
18	2.54	$2.20 \cdot 10^{-3}$	0.968
21	1.21	$1.69 \cdot 10^{-3}$	0.946
24	1.15	$1.64 \cdot 10^{-3}$	0.949
27	1.19	$1.41 \cdot 10^{-3}$	0.976
30	0.83	$1.24 \cdot 10^{-3}$	0.974

The estimated values of K_1 and K_2 constants in Peleg's equation are very similar to the values estimated for the rehydration process of convection dried apples, potato and carrot [5]. The value of the K_1 constant also decreased with rehydration temperature as mentioned in the work but this also depended on the duration of magnetron exposure (with the increase of the duration the value of K_1 decreased). The value of K_2 was only slightly dependent on both the exposure time and the temperature of the material.

K_2 constant can therefore be considered as a parameter characteristic for dried material subjected to rehydration.

The investigations undertaken show that Peleg's equation has a restricted application in the description of rehydration process of microwave dried carrot under reduced pressure. At the first rehydration stage, Peleg's equation approximates the process very well but at the next stage, serious deviations occur. This can be directly observed on the graphs. The values of relative errors, which do not exceed 5% at the first stage of the rehydration process yet approach 15% at the last stage, vindicate this opinion.

CONCLUSIONS

1. The process of the rehydration of microwave dried carrot, carried out at reduced pressure, can be described with Peleg's equation but only at the first stage of rehydration. At the second stage of rehydration, many more serious deviations can be observed.

2. The values of the K_1 and K_2 constants in Peleg's equation are of a similar order to the values obtained for the rehydration of carrot dried by different methods.

3. The value of K_1 depends much more on the duration of magnetron exposure than the value of K_2 . The effect of rehydration temperature on the value of K_2 constant has not been observed. The value of the K_1 constant decreased significantly with the growth of temperature.

REFERENCES

1. **Peleg M.:** An empirical model for describing moisture sorption curves. *J. Food Sci.*, 53, 4, 1216-1219, 1988.
2. **Szarycz M., Kramkowski R., Kamiński E., Jąłoszyński K.:** Kinetics of carrot drying in conditions of reduced pressure with microwave heating. *Acta Agrophisica*, 2002, 77, 147-154.
3. **Szarycz M.:** Mathematical models of the microwave-convection drying of agricultural raw materials using apples as an example (in Polish). *Zeszyty Naukowe Akademii Rolniczej Wrocław*, nr 420, 2001.
4. **Witrowa-Rajchert D.:** Rehydration as an index of the changes occurring in plant tissue during drying. (in Polish), Fundacja „Rozwój SGGW”, Warszawa 1999.
5. **Witrowa-Rajchert D., Kowalczyk K.:** Models of the rehydration process of dried plant tissue (in Polish). *Inżynieria Rolnicza*, Nr 12, 297-304, 2001.

BADANIE REHYDRACJI MARCHWI SUSZONEJ MIKROFALOWO
POD OBNIŻONYM CIŚNIENIEM

Ryszard Kramkowski, Marian Szarycz, Bogdan Stepień, Marcin Fidos

Instytut Inżynierii Rolniczej, Akademia Rolnicza, ul. Norwida 25, 53-375 Wrocław
e-mail: kramkowski@imr.ar.wroc.pl

Streszczenie. Badano kinetykę rehydracji marchwi odmiany Perfekcja suszonej mikrofalowo pod obniżonym ciśnieniem. Stosowano ciśnienie od 6 do 8 kPa oraz czas nagrzewania mikrofalami 18, 21, 24, 27 i 30 minut. Rehydrację prowadzono w wodzie o temperaturze 20°C w czasie od 0 do 180 minut i w wodzie o temperaturze 95°C w czasie od 0 do 120 minut. Otrzymane wyniki porównano z modelem Pelega.

Słowa kluczowe: rehydracja, podciśnienie, mikrofałe, marchew, równanie Pelega